

## Digital Compression Load Cell – Type DL 0-50 kg → 0-5.000 kg



### Special Features

- Robust capacitive technology
- High tolerance of up to 1.000 % overload
- Hermetically sealed to IP69K
- ATEX certified
- Low profile and hygienic design
- High resolution
- Withstands welding voltages and ESD
- Cable length up to 100 meters
- Load cell cable replaceable
- Calibration independent of cable length
- Easy mechanical and electrical installation
- 3 years warranty

### Technology

The shockproof digital load cell is based on a capacitive measurement principle where a non-contacting ceramic sensor is mounted inside the load cell body. As the load cell contains no moving parts and the sensor is not in contact with the load cell body, the load cell tolerates shocks, torsion, and very high overloads and side loads. Therefore, the mechanical installation of the load cell can be done without expensive and complicated mounting kits and overload protection devices.

The electrical installation of the digital load cell is pure plug-and-play as the signal from the non-contacting sensor is directly converted, compensated and calibrated by a microprocessor to a digital load cell output in grams, kilograms or Newton. Measurements and status codes are transmitted as RS485 data on a single wire coaxial cable (RG-58) which may be up to 100 meters long. The load cell cable can be replaced on-site if necessary.

The technology and mechanical design of the Eilersen load cells is covered worldwide by a number of patents.



### Capacities (in kg)

- 50
- 100
- 150
- 250
- 500
- 1.000
- 1.500
- 2.000
- 3.000
- 4.000
- 5.000

### Options

- ATEX (Zone 1, 2, 21, 22) version type DLA
- ATEX II 2G Ex ia IIC T6
- ATEX II 2D Ex iaD 21 T85°C
- Base plate available

### Applications

- Tank and Silo weighing
- Process weighing
- Filling, batching, sorting and dosing equipment
- Level measurement
- Platform scales
- Hopper scales
- Belt scales
- Offshore/Marine applications
- Heavy duty applications

## Specifications

Parameter	Unit	0,10	0,05	0,025
Rated capacity (E <sub>max</sub> )	Kg	50, 100, 150, 250, 500, 1.000 1.500, 2.000, 3.000, 4.000, 5.000		
Safe overload limit	% of E <sub>max</sub>	300 to 1.000		
Safe sideload limit	% of E <sub>max</sub>	500 to 2.000		
Minimum dead load	% of E <sub>max</sub>	0		
Accuracy	% of E <sub>max</sub>	0,06	0,04	0,020
Repeatability	% of E <sub>max</sub>	0,02	0,01	0,008
Hysteresis	% of E <sub>max</sub>	0,06	0,04	0,020
Creep 30 min.	% of E <sub>max</sub>	0,06	0,04	0,020
Temperature effect on zero	% / 10 °C	0,05	0,03	0,009
Temperature effect on sensitivity	% / 10 °C	0,05	0,03	0,009
Compensated temperature range	°C	-10 to 50		
Operating temperature range	°C	-50 to 80 (100*)		
Deflection at E <sub>max</sub>	mm	Max 0,10		
Measuring rate	Hz	Up to 1.000		
Supply	Vdc	24 +/- 10%		
Internal resolution	Bit	24		
Material		Stainless Steel 17-4 PH and AISI 316		
Protection		IP69K		
Cable		6 meter standard coaxial RG-58 (ø 6 mm) with BNC connector		
Maximum cable length	meters	100		
Weight	grams	1.700		
Standard output		RS485		
Output options		Profibus DP, DeviceNet, EtherNet/IP, Modbus ASCII/RTU, 4-20 mA, 0-10 V		
Warranty		3 years		

\* with Teflon cable

## Dimensions (in mm)

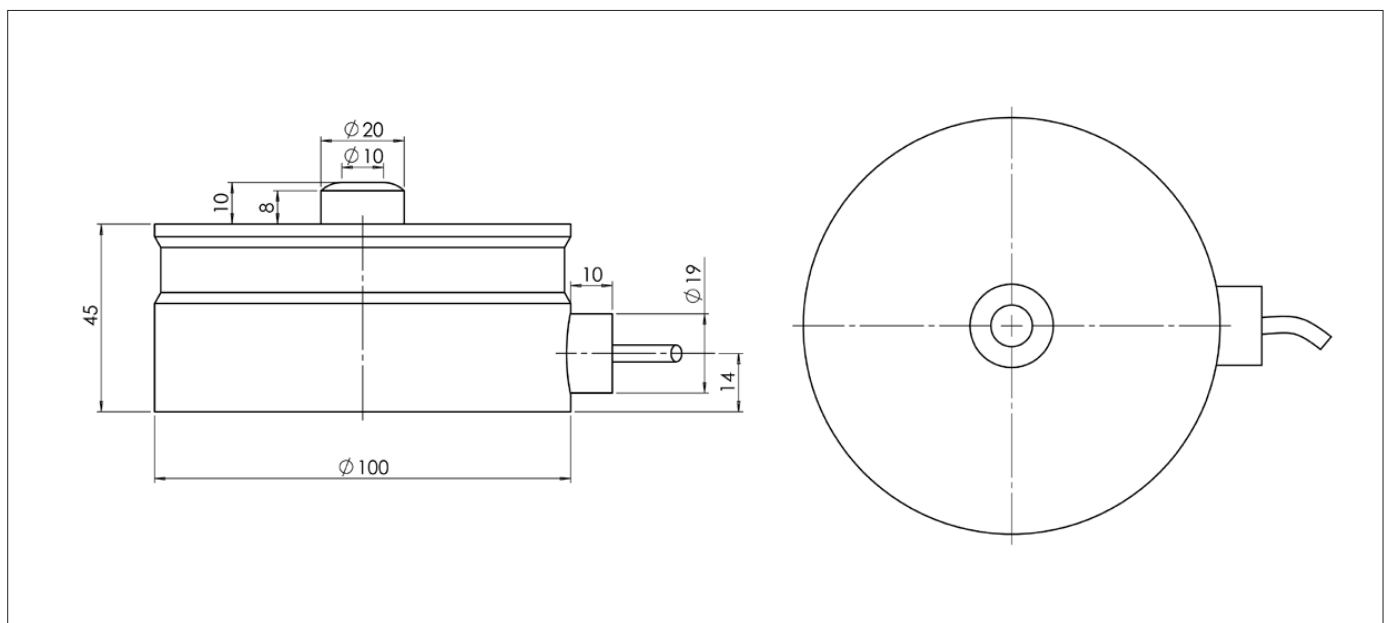

Dealer/Distributor:

┌

└

### Order Information

Type	Capacity	Accuracy
------	----------	----------

### Example

DL	2.000 kg	0,05 %
----	----------	--------

┌

└

**Disclaimer and Legal Information:** The information in this document is provided in connection with products supplied by Eilersen Electric A/S and affiliated companies ("Eilersen"). No license, expressed or implied, to any intellectual property rights is granted by this document. Eilersen assumes no liability and disclaims any expressed or implied warranty, relating to sale and/or use of Eilersen products including liability or warranties relating to fitness for a particular purpose, or infringement of any patent, copyright or other intellectual property right. The information in this document is subject to change without prior notice, and Eilersen assumes no responsibility or liability for any errors or inaccuracies that may appear in this document.